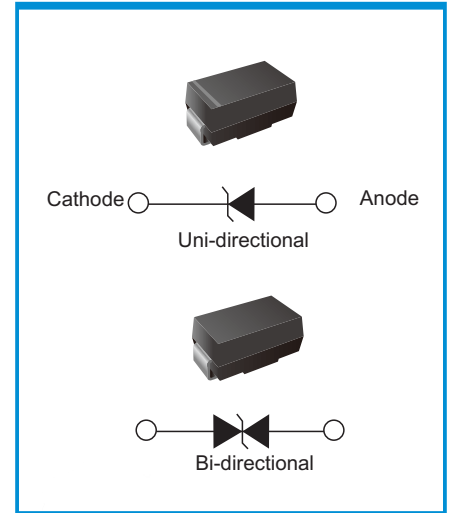

# Transient Voltage Suppressors (TVS) DataSheet

## Features

- 500W peak pulse power capability at 10/1000 $\mu$ s waveform, repetition rate (duty cycle): 0.01%
- Typical  $I_R$  less than 1 $\mu$ A above 10V.
- High Temperature soldering guaranteed: 265 $^{\circ}$ C
- Plastic package has underwriters laboratory flammability 94V-0
- Meets MSL level 1, per J-STD-020.
- Glass passivated junction
- Low incremental surge resistance
- Excellent clamping capability
- Fast response time

**Functional Diagram**

## Mechanical Data

- Case: JEDEC DO-214AC Moulded plastic
- Terminal: Axial leads, solderable per MIL-STD-750, Method 2026
- Polarity: For uni-directional types the band denotes cathode end, no marking on bi-directional types
- Mounting Position: Any
- Weight: 0.07g

## Applications

- I/O interface
- Vcc bus
- AC/DC power supply
- Low frequency signal transmission line (RS232, RS485, etc.)

## Maximum Ratings and Characteristics

Ratings at 25 $^{\circ}$ C ambient temperature unless otherwise specified.

Rating	Symbol	Value	Units
Peak pulse power dissipation at 10/1000 $\mu$ s waveform (Note1, Fig.1)	$P_{PPM}$	Minimum 500	Watts
Peak pulse current of at 10/1000 $\mu$ s waveform (Note 1, Fig.3)	$I_{PPM}$	See Table	Amps
Steady state power dissipation at $T_L=75^{\circ}$ C (Fig.5)	$P_{M(AV)}$	3.3	Watts
Peak forward surge current, 8.3ms single half sine-wave superimposed on rated load, (JEDEC Method) (Note2, Fig.6)	$I_{FSM}$	70	Amps
Operating junction and Storage Temperature Range.	$T_J, T_{STG}$	-55 to +175	$^{\circ}$ C
Typical thermal resistance junction to lead	$R_{\theta JL}$	20	$^{\circ}$ C/W
Typical thermal resistance junction to ambient	$R_{\theta JA}$	75	$^{\circ}$ C/W

Notes: 1. Non-repetitive current pulse, per Fig.3 and derated above  $T_A=25^{\circ}$ C per Fig.2.

2. 8.3ms single half sine-wave, or equivalent square wave, duty cycle=4 pulses per minutes maximum.

**Electrical Characteristics (T<sub>A</sub>=25°C)**

Part Number		Device Marking Code	Reverse Stand-Off Voltage	Breakdown Voltage @I <sub>T</sub>	Breakdown Voltage @I <sub>T</sub>	Test Current	Maximum Clamping Voltage@I <sub>PP</sub>	Peak Pulse Current	Reverse Leakage @V <sub>RWM</sub>
UNI-POLAR	BI-POLAR		V <sub>RWM</sub> (V)	V <sub>BR MIN</sub> (V)	V <sub>BR MAX</sub> (V)	I <sub>T</sub> (mA)	V <sub>C</sub> (V)	I <sub>PP</sub> (A)	I <sub>R</sub> (μA)
LTVA5.0AH	LTVA5.0CH	5H	5	6.4	7	10	9.2	55.4	600
LTVA6.0AH	LTVA6.0CH	6H	6	6.67	7.37	10	10.3	49.5	600
LTVA6.5AH	LTVA6.5CH	6H5	6.5	7.22	7.98	10	11.2	45.5	400
LTVA7.0AH	LTVA7.0CH	7H	7	7.78	8.6	10	12	42.5	150
LTVA7.5AH	LTVA7.5CH	7H5	7.5	8.33	9.21	1	12.9	39.5	50
LTVA8.0AH	LTVA8.0CH	8H	8	8.89	9.83	1	13.6	37.5	25
LTVA8.5AH	LTVA8.5CH	8H5	8.5	9.44	10.4	1	14.4	35.4	10
LTVA9.0AH	LTVA9.0CH	9H	9	10	11.1	1	15.4	33.1	5
LTVA10AH	LTVA10CH	10H	10	11.1	12.3	1	17	30	3
LTVA11AH	LTVA11CH	11H	11	12.2	13.5	1	18.2	28	1
LTVA12AH	LTVA12CH	12H	12	13.3	14.7	1	19.9	25.6	1
LTVA13AH	LTVA13CH	13H	13	14.4	15.9	1	21.5	23.7	1
LTVA14AH	LTVA14CH	14H	14	15.6	17.2	1	23.2	22	1
LTVA15AH	LTVA15CH	15H	15	16.7	18.5	1	24.4	20.9	1
LTVA16AH	LTVA16CH	16H	16	17.8	19.7	1	26	19.6	1
LTVA17AH	LTVA17CH	17H	17	18.9	20.9	1	27.6	18.5	1
LTVA18AH	LTVA18CH	18H	18	20	22.1	1	29.2	17.5	1
LTVA20AH	LTVA20CH	20H	20	22.2	24.5	1	32.4	15.7	1
LTVA22AH	LTVA22CH	22H	22	24.4	26.9	1	35.5	14.4	1
LTVA24AH	LTVA24CH	24H	24	26.7	29.5	1	38.9	13.1	1
LTVA26AH	LTVA26CH	26H	26	28.9	31.9	1	42.1	12.1	1
LTVA28AH	LTVA28CH	28H	28	31.1	34.4	1	45.4	11.2	1
LTVA30AH	LTVA30CH	30H	30	33.3	36.8	1	48.4	10.5	1
LTVA33AH	LTVA33CH	33H	33	36.7	40.6	1	53.3	9.6	1
LTVA36AH	LTVA36CH	36H	36	40	44.2	1	58.1	8.8	1
LTVA40AH	LTVA40CH	40H	40	44.4	49.1	1	64.5	7.9	1
LTVA43AH	LTVA43CH	43H	43	47.8	52.8	1	69.4	7.3	1
LTVA45AH	LTVA45CH	45H	45	50	55.3	1	72.7	7	1
LTVA48AH	LTVA48CH	48H	48	53.3	58.9	1	77.4	6.6	1
LTVA51AH	LTVA51CH	51H	51	56.7	62.7	1	82.4	6.2	1
LTVA54AH	LTVA54CH	54H	54	60	66.3	1	87.1	5.9	1
LTVA58AH	LTVA58CH	58H	58	64.4	71.2	1	93.6	5.4	1
LTVA60AH	LTVA60CH	60H	60	66.7	73.7	1	96.8	5.3	1
LTVA64AH	LTVA64CH	64H	64	71.1	78.6	1	103	5	1
LTVA70AH	LTVA70CH	70H	70	77.8	86	1	113	4.5	1
LTVA75AH	LTVA75CH	75H	75	83.3	92.1	1	121	4.2	1
LTVA78AH	LTVA78CH	78H	78	86.7	95.8	1	126	4	1
LTVA85AH	LTVA85CH	85H	85	94.4	104	1	137	3.7	1
LTVA90AH	LTVA90CH	90H	90	100	111	1	146	3.5	1
LTVA100AH	LTVA100CH	100H	100	111	123	1	162	3.1	1
LTVA110AH	LTVA110CH	110H	110	122	135	1	177	2.9	1
LTVA120AH	LTVA120CH	120H	120	133	147	1	193	2.6	1
LTVA130AH	LTVA130CH	130H	130	144	159	1	209	2.4	1
LTVA150AH	LTVA150CH	150H	150	167	185	1	243	2.1	1
LTVA160AH	LTVA160CH	160H	160	178	197	1	259	2	1
LTVA170AH	LTVA170CH	170H	170	189	209	1	275	1.9	1
LTVA180AH	LTVA180CH	180H	180	201	222	1	292	1.7	1
LTVA190AH	LTVA190CH	190H	190	211	233	1	308	1.6	1
LTVA200AH	LTVA200CH	200H	200	224	247	1	324	1.5	1
LTVA210AH	LTVA210CH	210H	210	237	263	1	340	1.5	1
LTVA220AH	LTVA220CH	220H	220	246	272	1	356	1.4	1

Notes: For bidirectional type having V<sub>R</sub> of 10V and less, the I<sub>R</sub> limit is double.

## Ratings and Characteristic Curves ( $T_A = 25^\circ\text{C}$ unless otherwise noted)

Figure 1. Peak Pulse Power Rating Curve

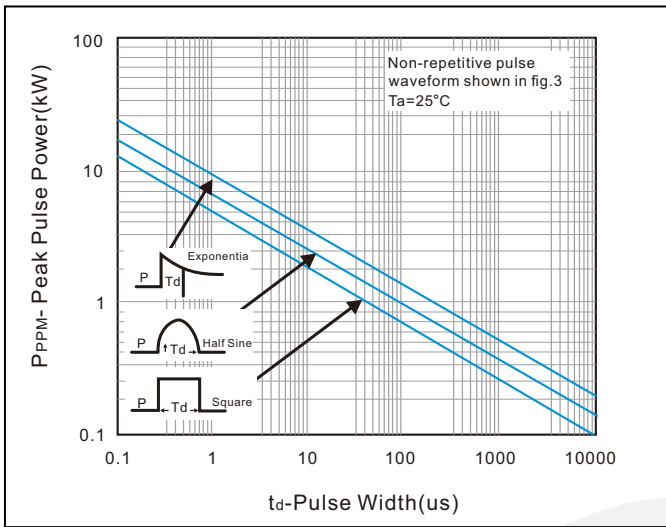

Figure 4. Typical Junction Capacitance

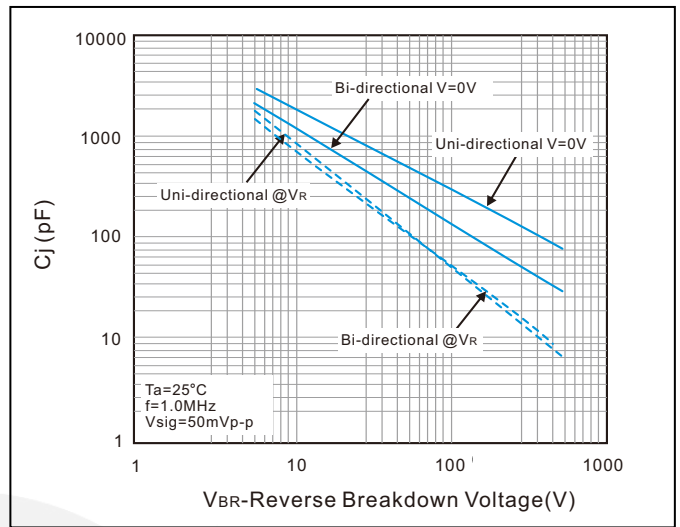

Figure 2. Pulse Derating Curve

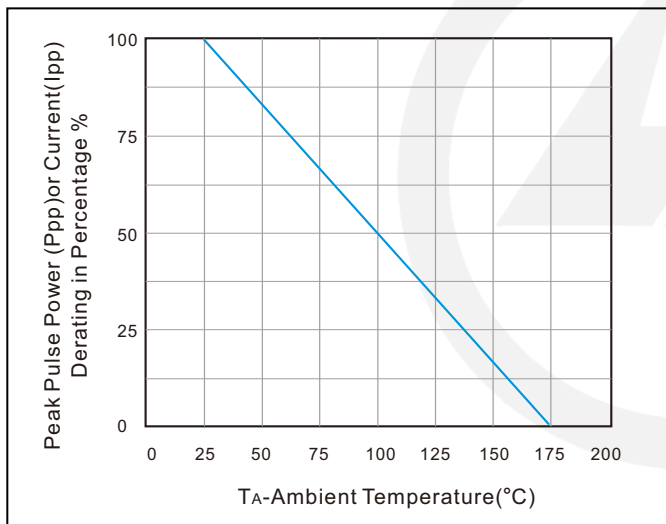

Figure 5. Steady State Power Dissipation Derating Curve

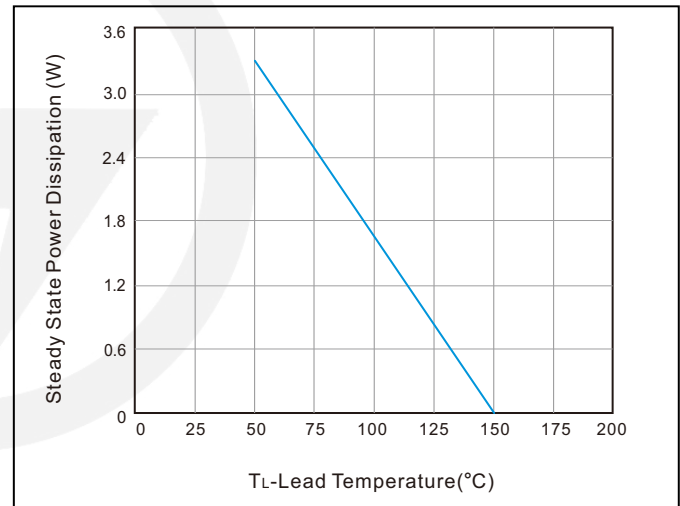

Figure 3. Pulse Waveform

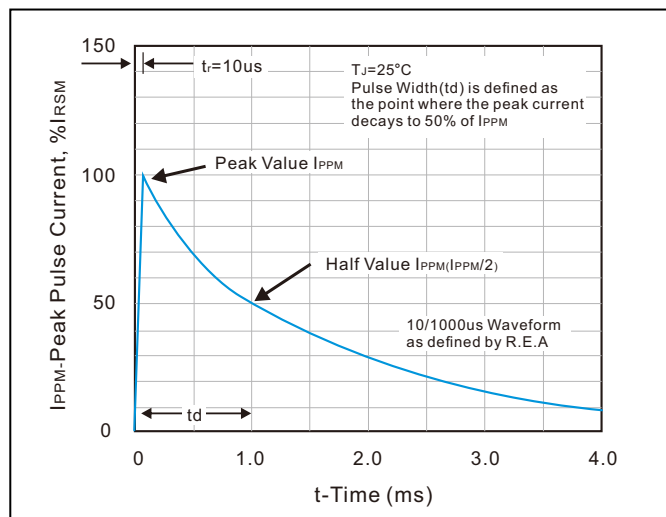
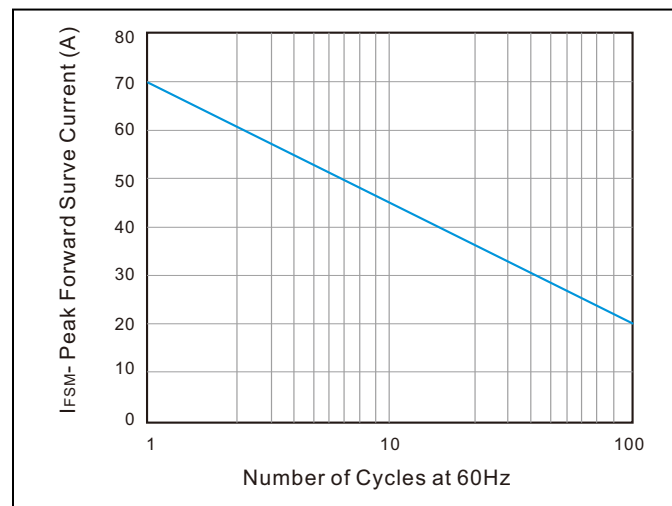
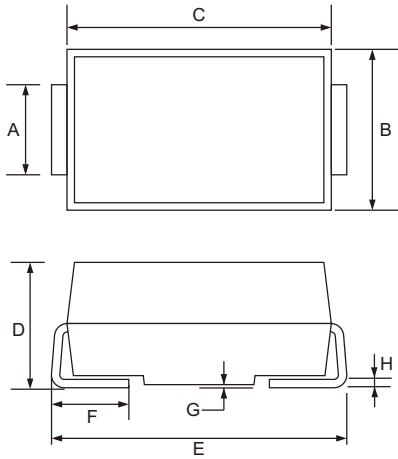

Figure 6. Maximum Non-Repetitive Forward Surge Current Uni-Directional Only



### SMA Package Outline



Unit : mm

SYMBOL	DIMENSIONS	
	MIN.	MAX.
A	1.25	1.65
B	2.30	2.79
C	4.00	4.75
D	1.90	2.50
E	4.70	5.28
F	0.76	1.52
G	0.203 TYP.	
H	0.15	0.31

### SMA Suggested Pad Layout

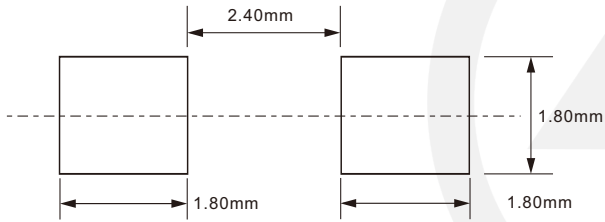

Note:

1. Controlling dimension: in millimeters.
2. General tolerance:  $\pm 0.05\text{mm}$
3. The pad layout is for reference purpose only.

## Recommended Soldering Conditions

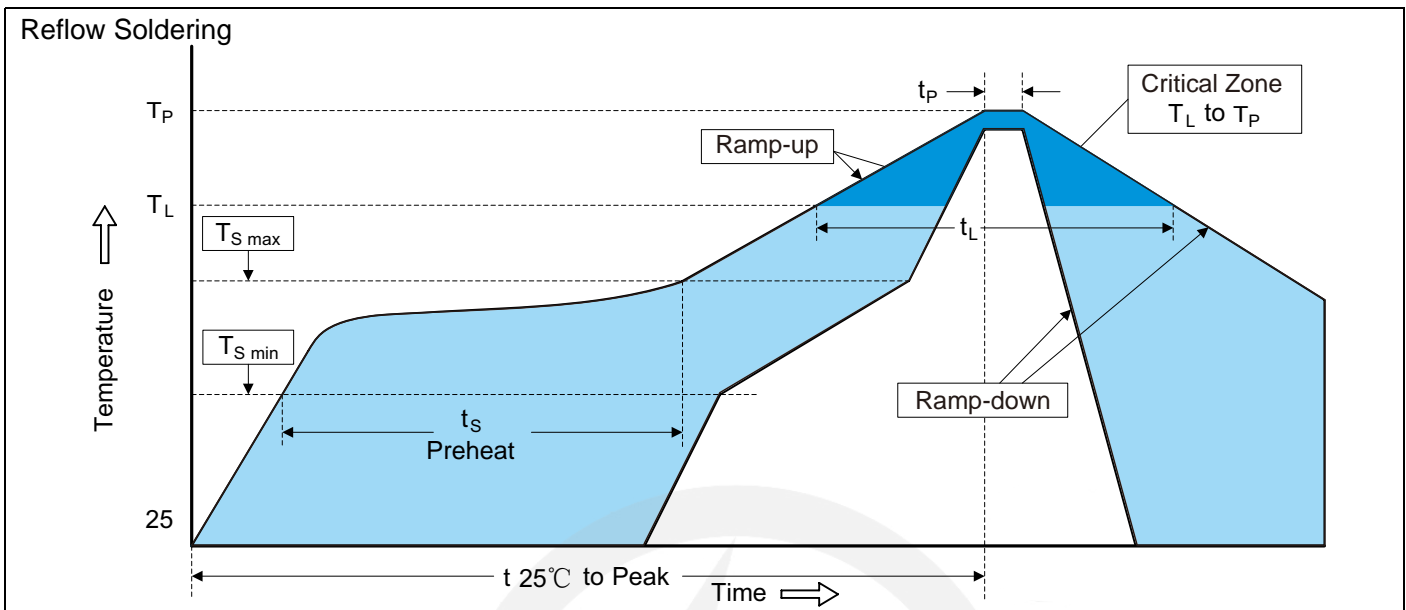

### Recommended Conditions

Profile Feature	Pb-Free Assembly
Average ramp-up rate (T <sub>L</sub> to T <sub>P</sub> )	3°C/second max.
Preheat -Temperature Min (T <sub>S min</sub> ) -Temperature Max (T <sub>S max</sub> ) -Time (min to max) (t <sub>s</sub> )	150°C 200°C 60-180 seconds
T <sub>S max</sub> to T <sub>L</sub> -Ramp-up Rate	3°C/second max.
Time maintained above: -Temperature (T <sub>L</sub> ) -Time (t <sub>L</sub> )	217°C 60-150 seconds
Peak Temperature (T <sub>P</sub> )	260°C
Time within 5°C of actual Peak Temperature (t <sub>P</sub> )	20-40 seconds
Ramp-down Rate	6°C/second max.
Time 25°C to Peak Temperature	8 minutes max.

### Packaging

13" Reel

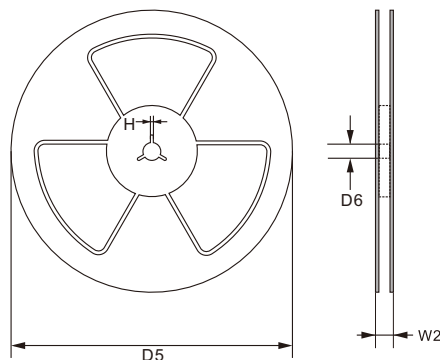

D5      Φ330.0±2.0

D6      Φ13.5±0.5

H      2.5±1.0

W2      16.0±2.0

Quantity: 5000PCS